



**THE GARDEN FURNITURE CENTRE LTD**  
EST. 1999

# PRODUCTION INSTRUCTION

RETRACTABLE BIOCLIMATIC  
PERGOLA SYSTEM

2022

---

W:3500mm \* P:5000mm

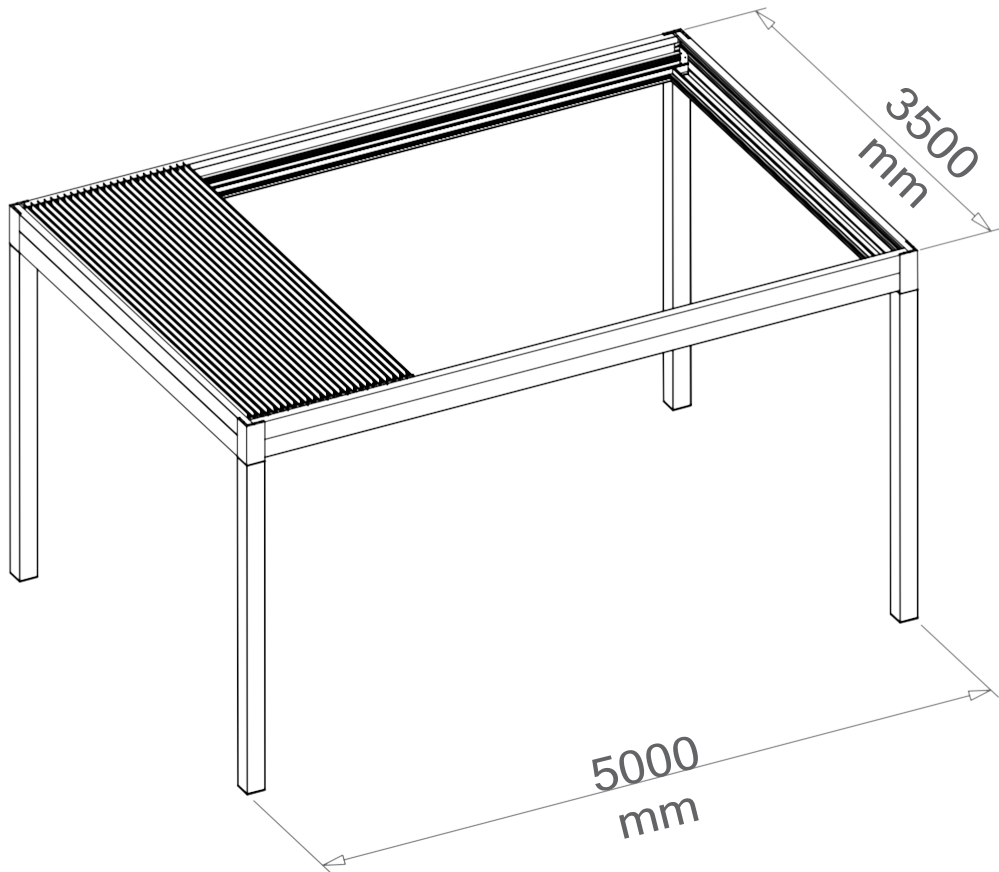



You should follow the steps listed below for easier and correct installation when you are installing the "Bioclimatic System" which will be on sub-assembly phase.



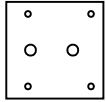
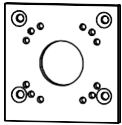
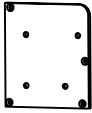
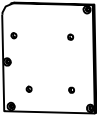

### *Package Content*

- Rafter Group
- Beam Group
- Front Post Group
- Drive Profiles Group
- Lamel Group

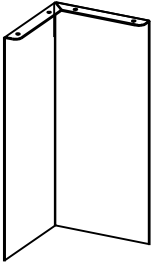
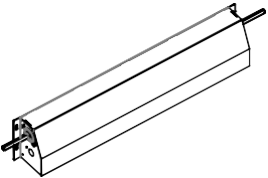
### *Installation Steps*

- 1- Installation of front post and beam group
- 2- Installation of Rafter Group and Beam Group
- 3- Fix (first) lamel Installation
- 4- Intermediate Lamel Installation
- 5- Drive Lamel Installation
- 6- Installation and connection of lamels to the drive profile group
- 7- Installation and connection of Motor to drive profile group
- 8- Beam And Rafter Groups Cover Installation
- 9- Corner Covers Installation

CODE	DRAWING	DRAWING	Pcs
1		Post Connection Part 160x160	x 4
2		Post Connect Part 160x160	x 4
3		Rafter & Beam Connection Part (Right)	x 2
4		Rafter & Beam Connection Part (Left)	x 2
5		Rafter - Beam Connect Part	x 8
6		Corner Cover Cap	x 4
7		RTS Motor	x 1

CODE	DRAWING	DRAWING	Pcs
8		Light Panel	x 1
9		Muff	x 4
10		Remote Control	x 1
11		M10x25mm Inox Imbus Bolt (4 for per post group)	x 16
12		M10 Galvanized washer (4 for per post group)	x 16

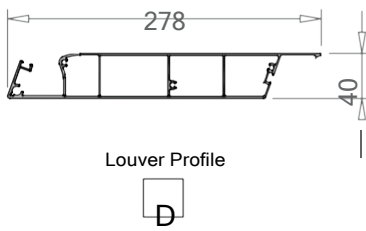
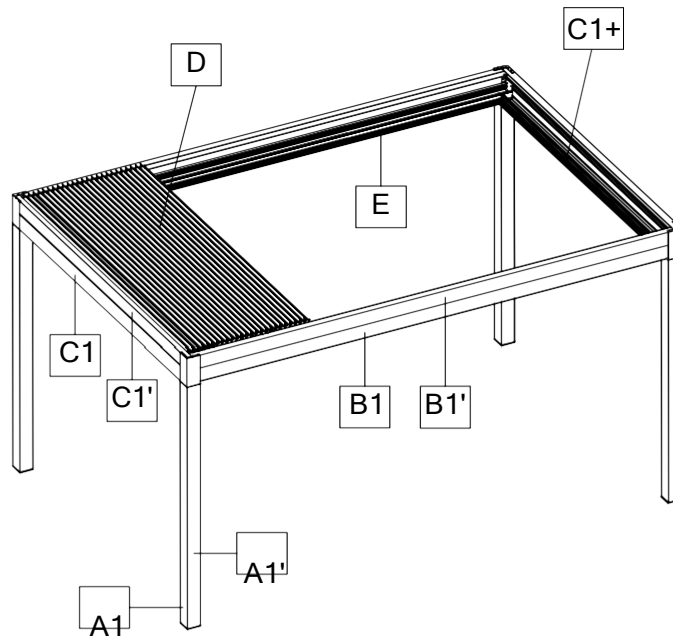

Louver Profile

D

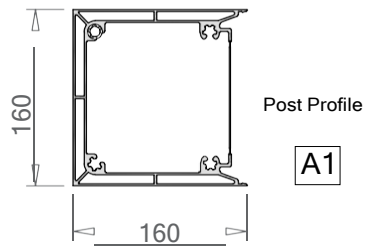

Post Profile

A1

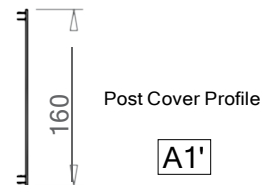

Post Cover Profile

A1'

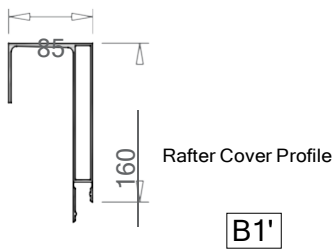

Rafter Cover Profile

B1'

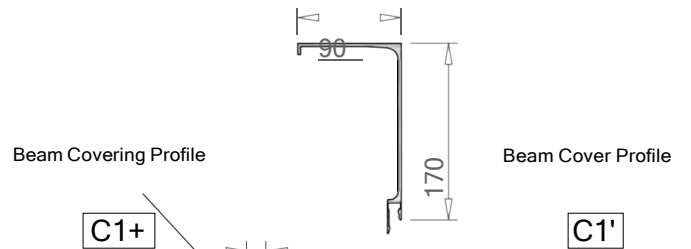

Beam Covering Profile

Beam Cover Profile

C1'

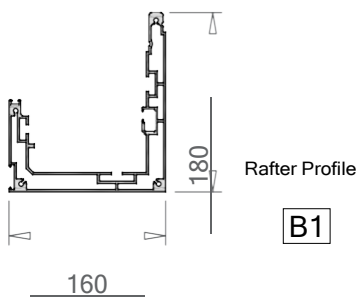

Rafter Profile

B1

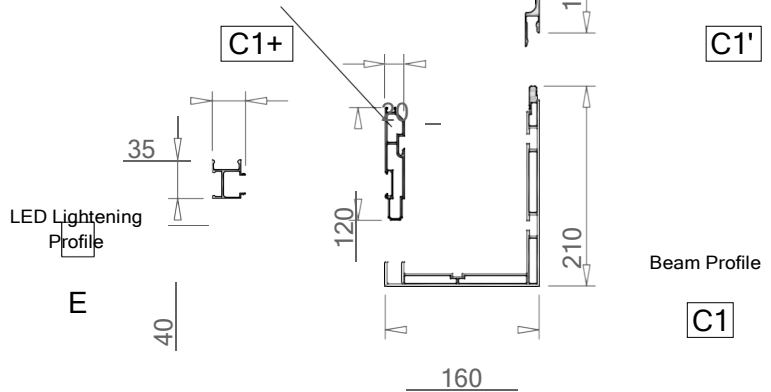

LED Lightening Profile

E

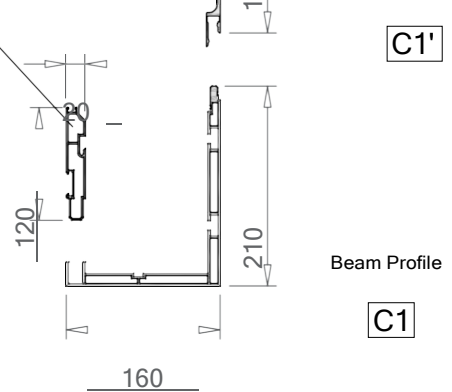

Beam Profile

C1

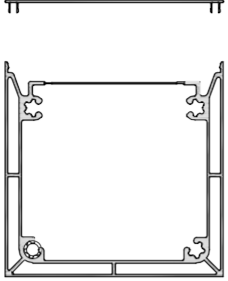
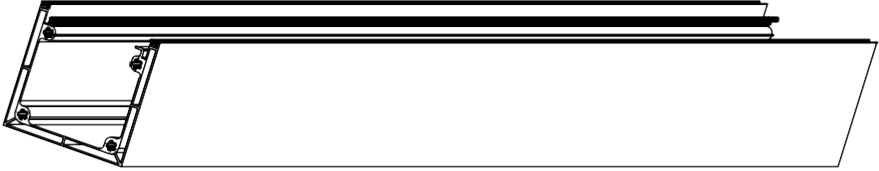
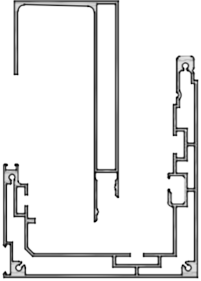
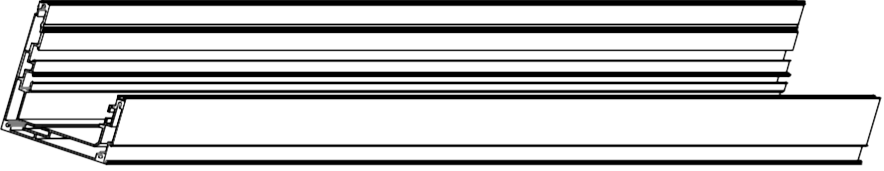
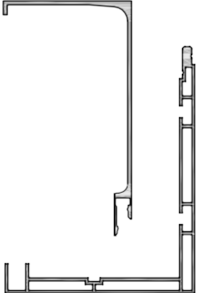
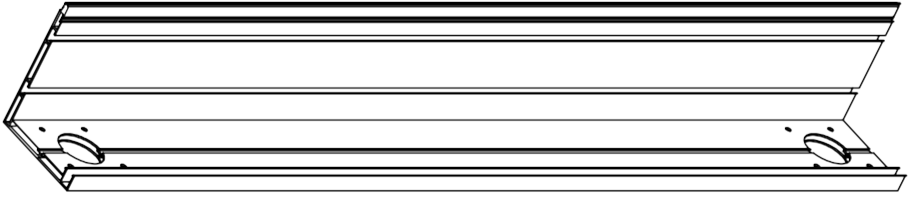
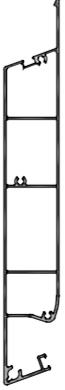
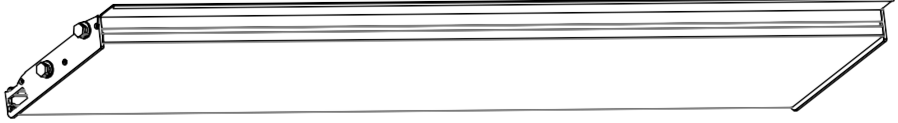
CODE	DRAWING	DRAWING	Pcs
A1 & A1'		<p data-bbox="826 387 1134 427">Post &amp; Post Cover</p> 	x 4
B1 & B1'		<p data-bbox="799 768 1161 808">Rafter &amp; Rafter Cover</p> 	x 2
C1 & C1'		<p data-bbox="804 1149 1157 1189">Beam &amp; Beam Cover</p> 	x 2
D			x 25

Aluminium profile groups assembly position.

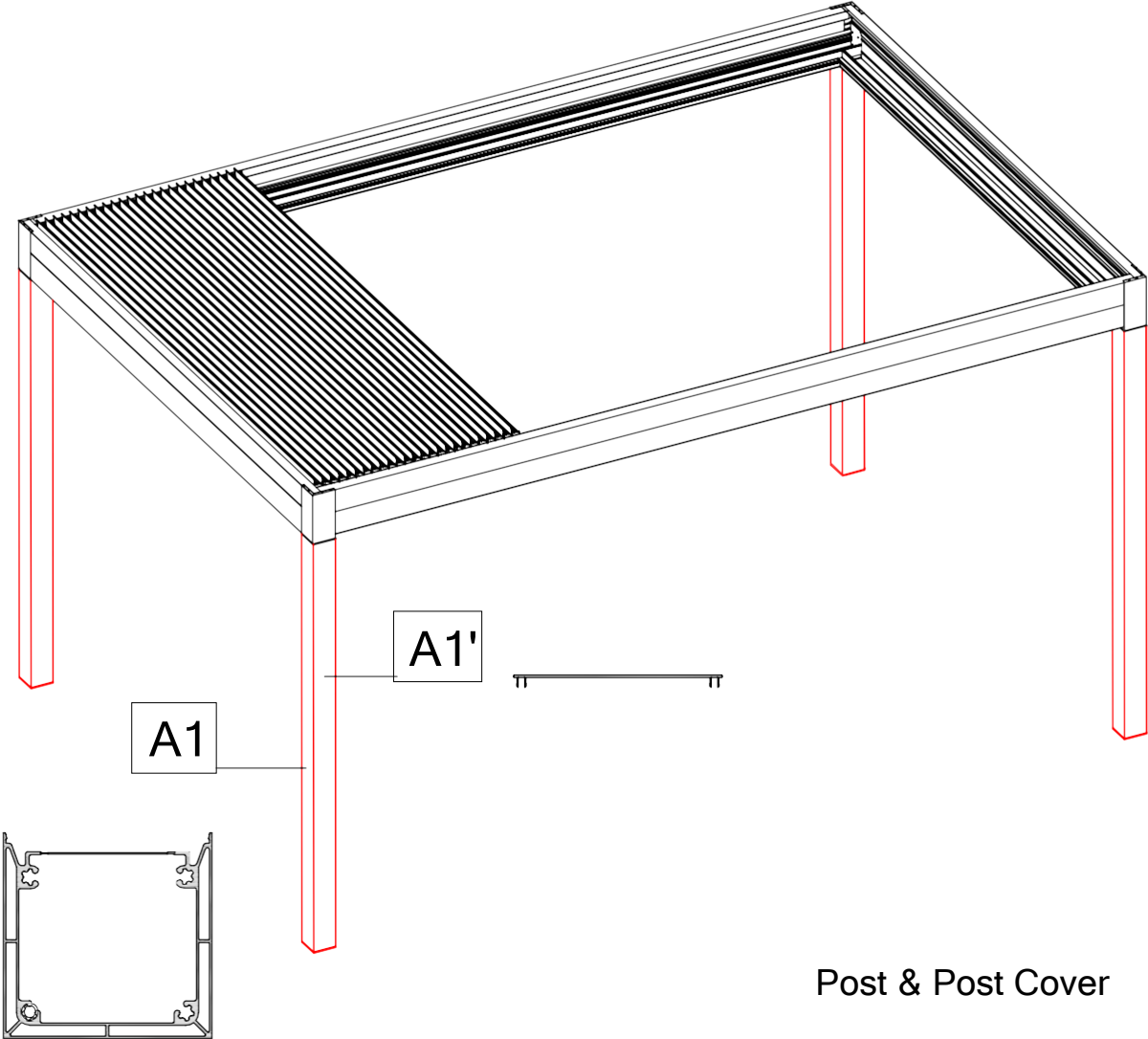



Aluminium profile groups assembly position.

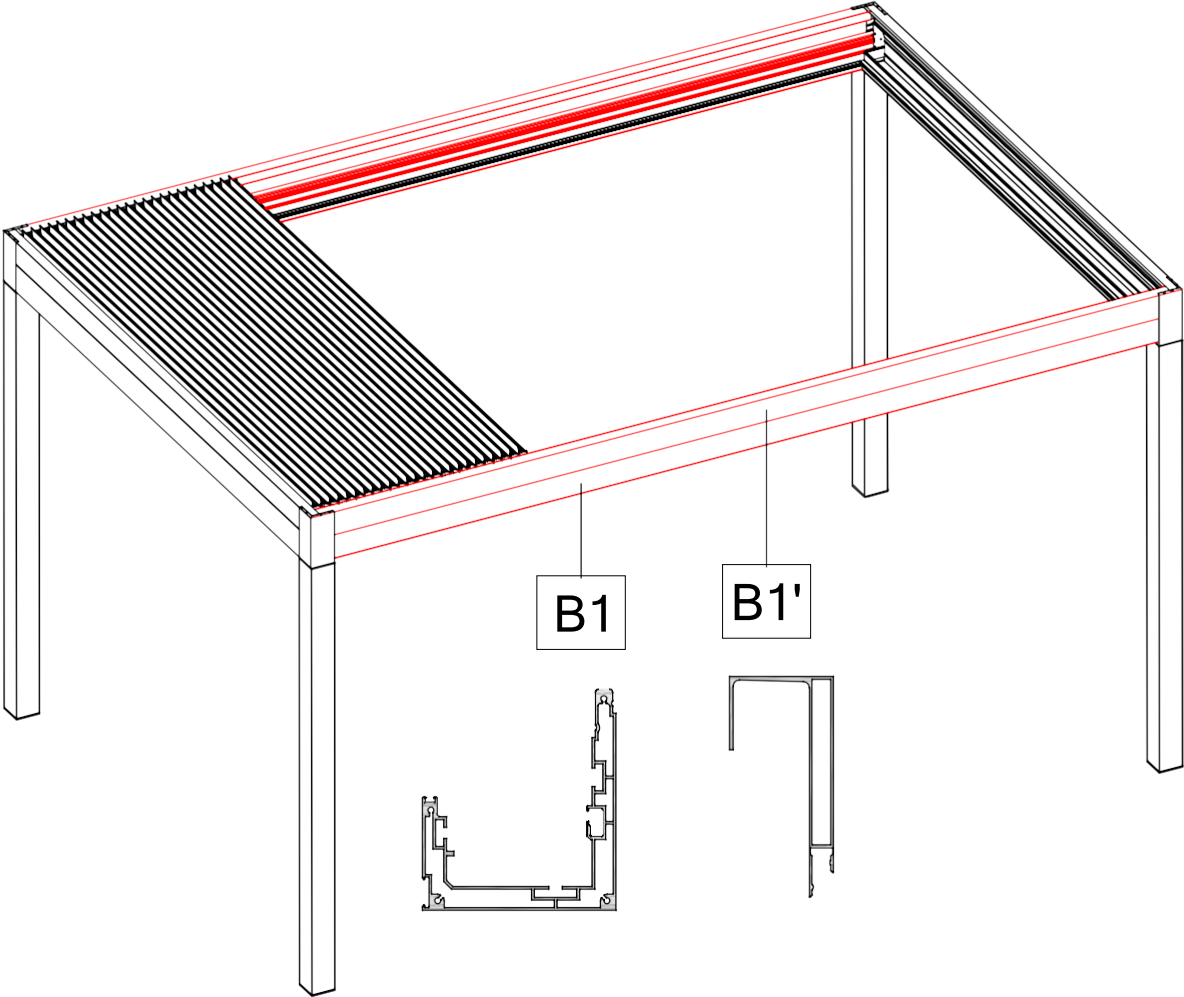

Rafter & Rafter Cover

Aluminium profile groups assembly position.

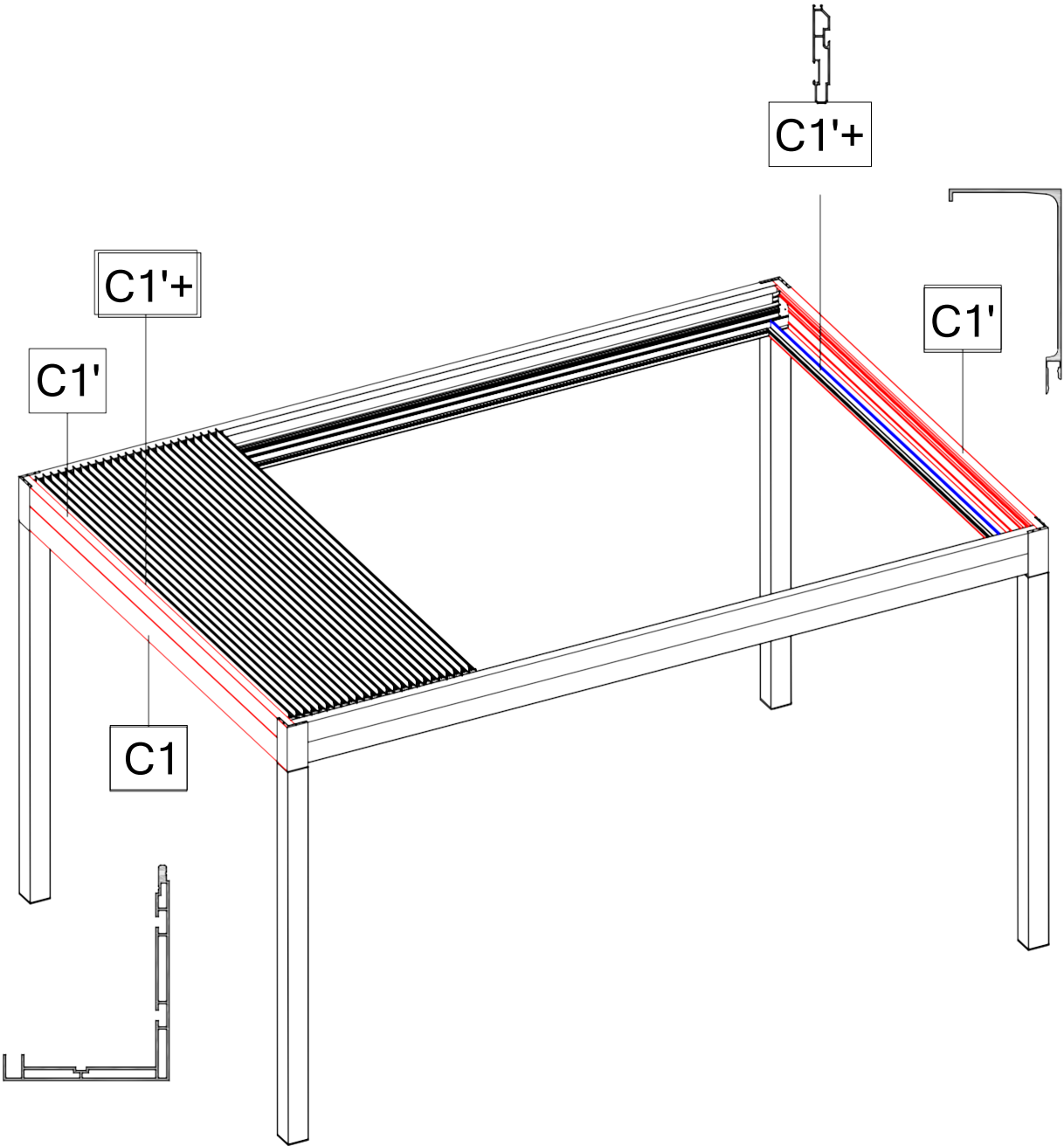

Beam & Beam Cover

Aluminium profile groups assembly position.

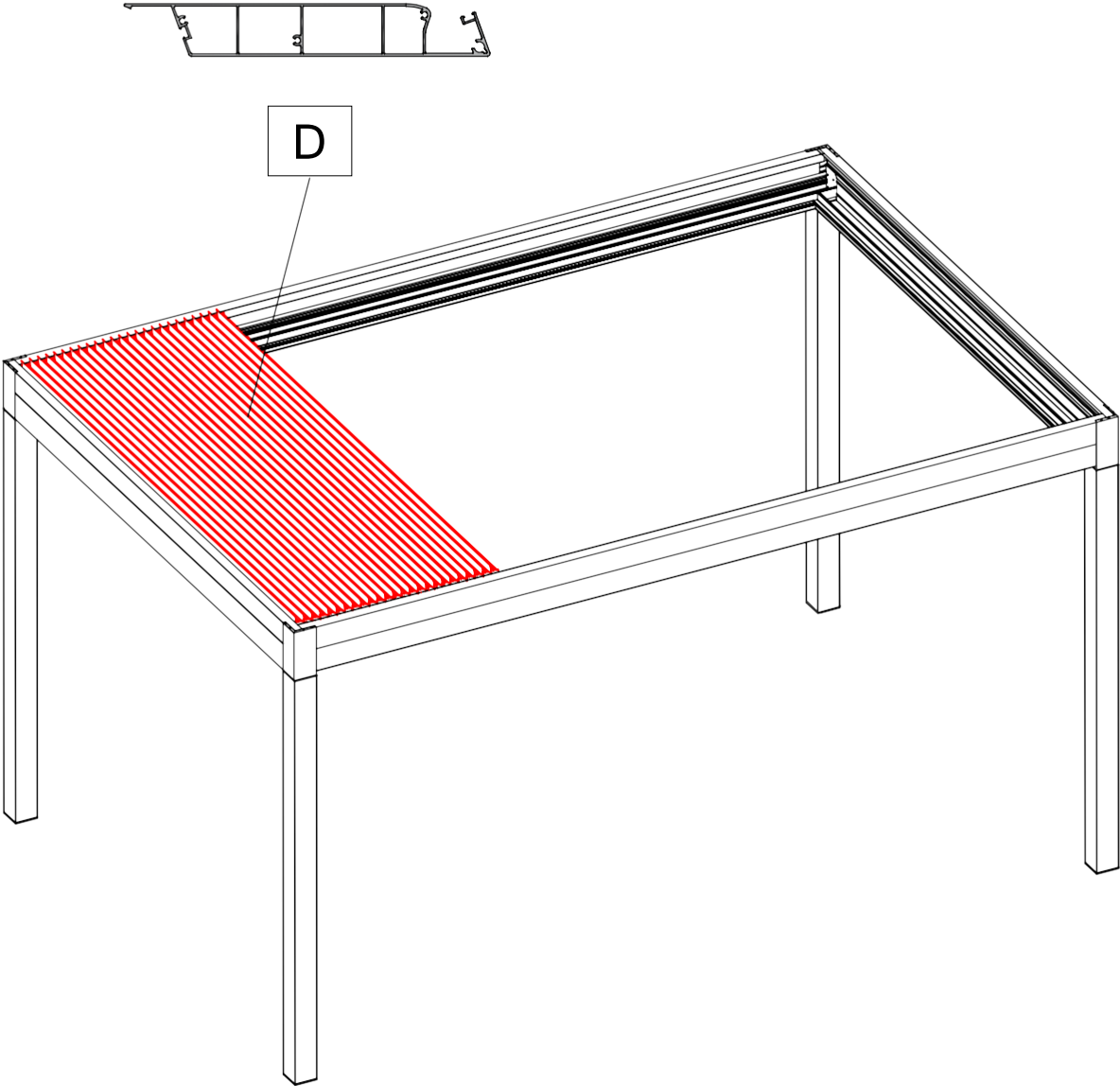

Louver Profile

Aluminium profile groups assembly position.

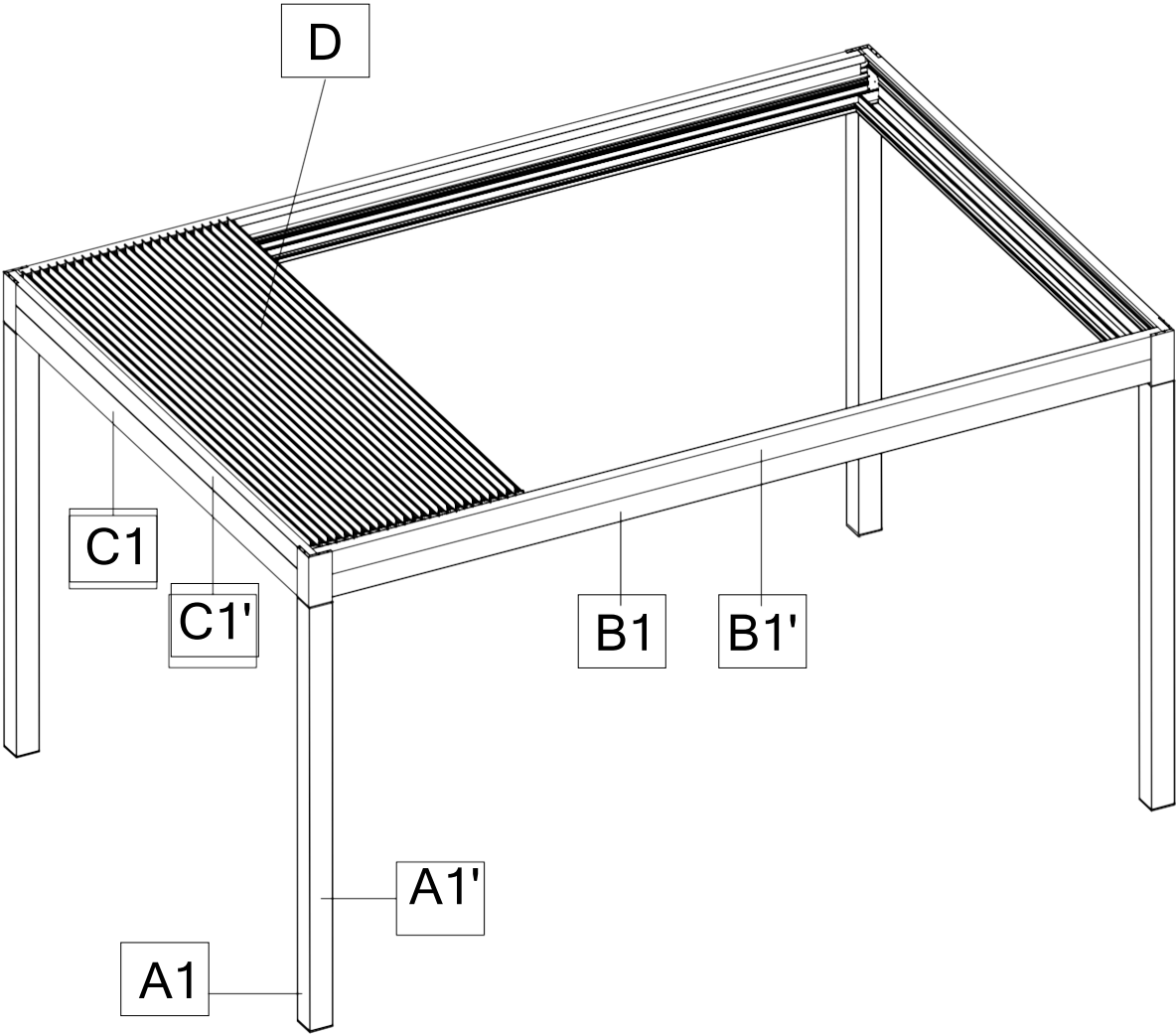

System position & plan.

COLUMN B

COLUMN C

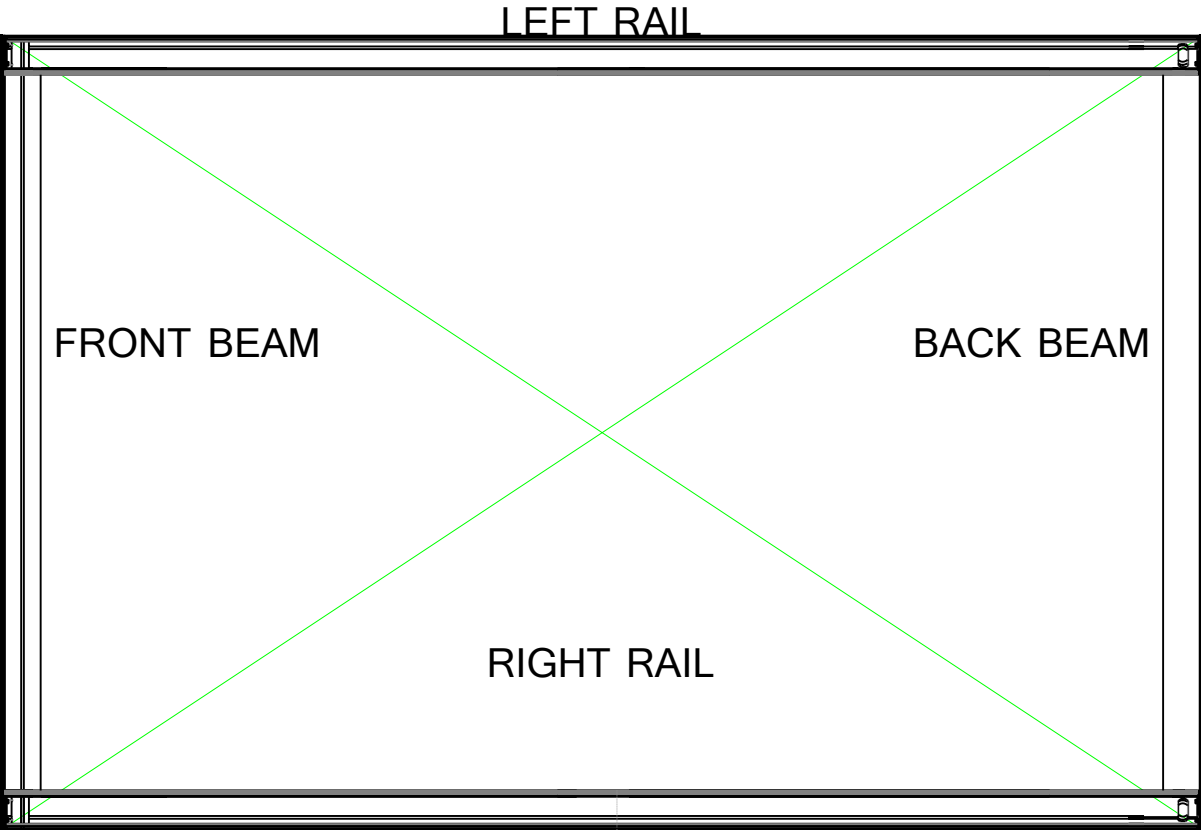

COLUMN A

COLUMN D

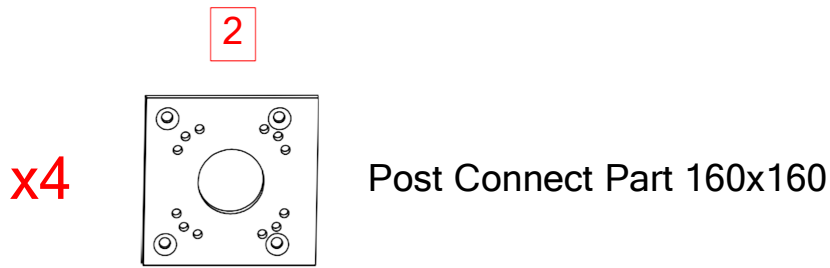

Step 2

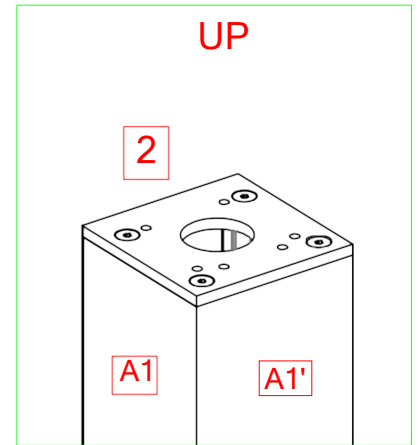
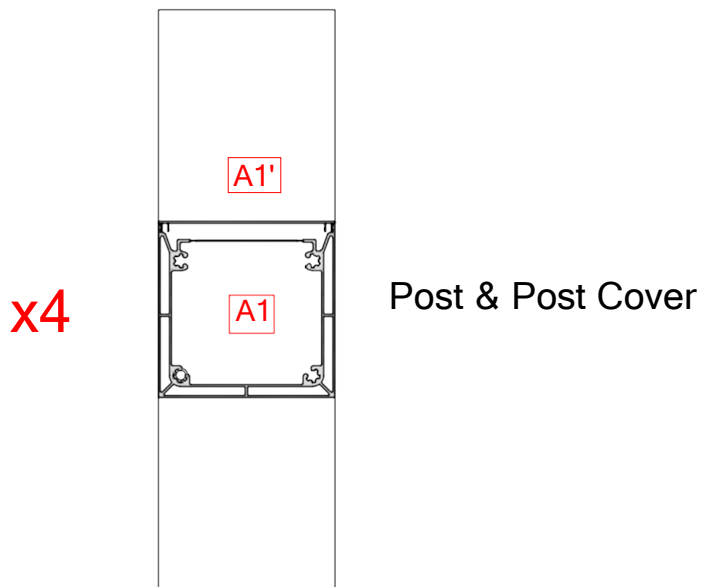

Step 1

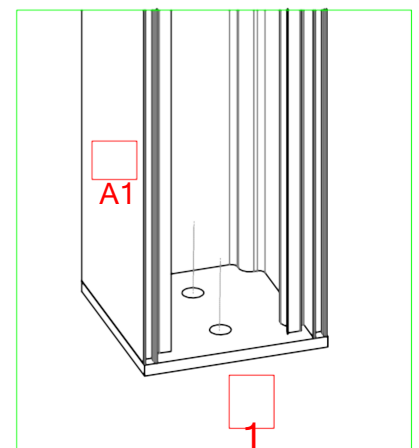

COLUMN A - B - C - D

## Step 1/2

M10x25 Imbus Inox Bolt x16  
M10 Inox Washer x16

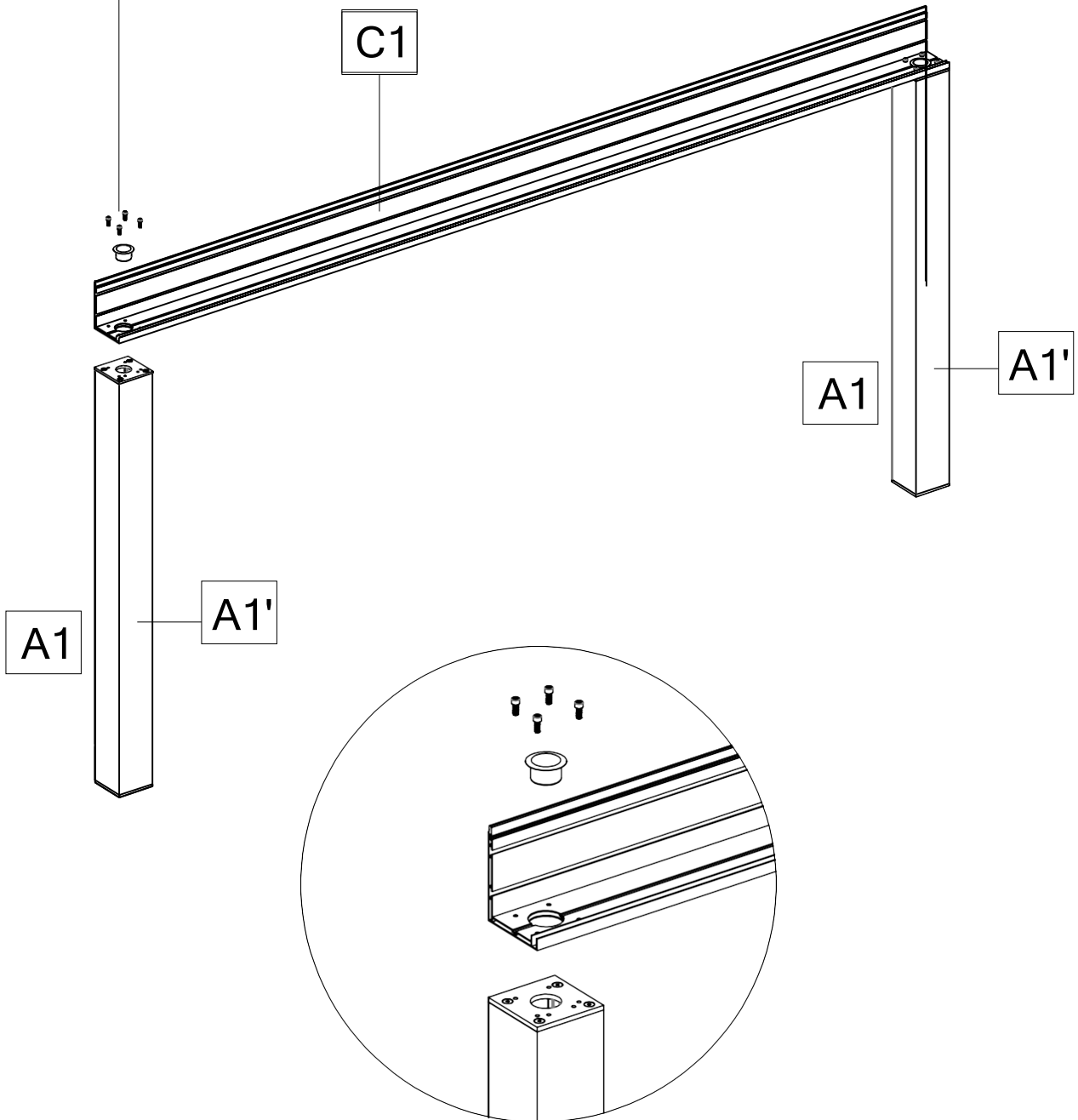

## Step 2/2

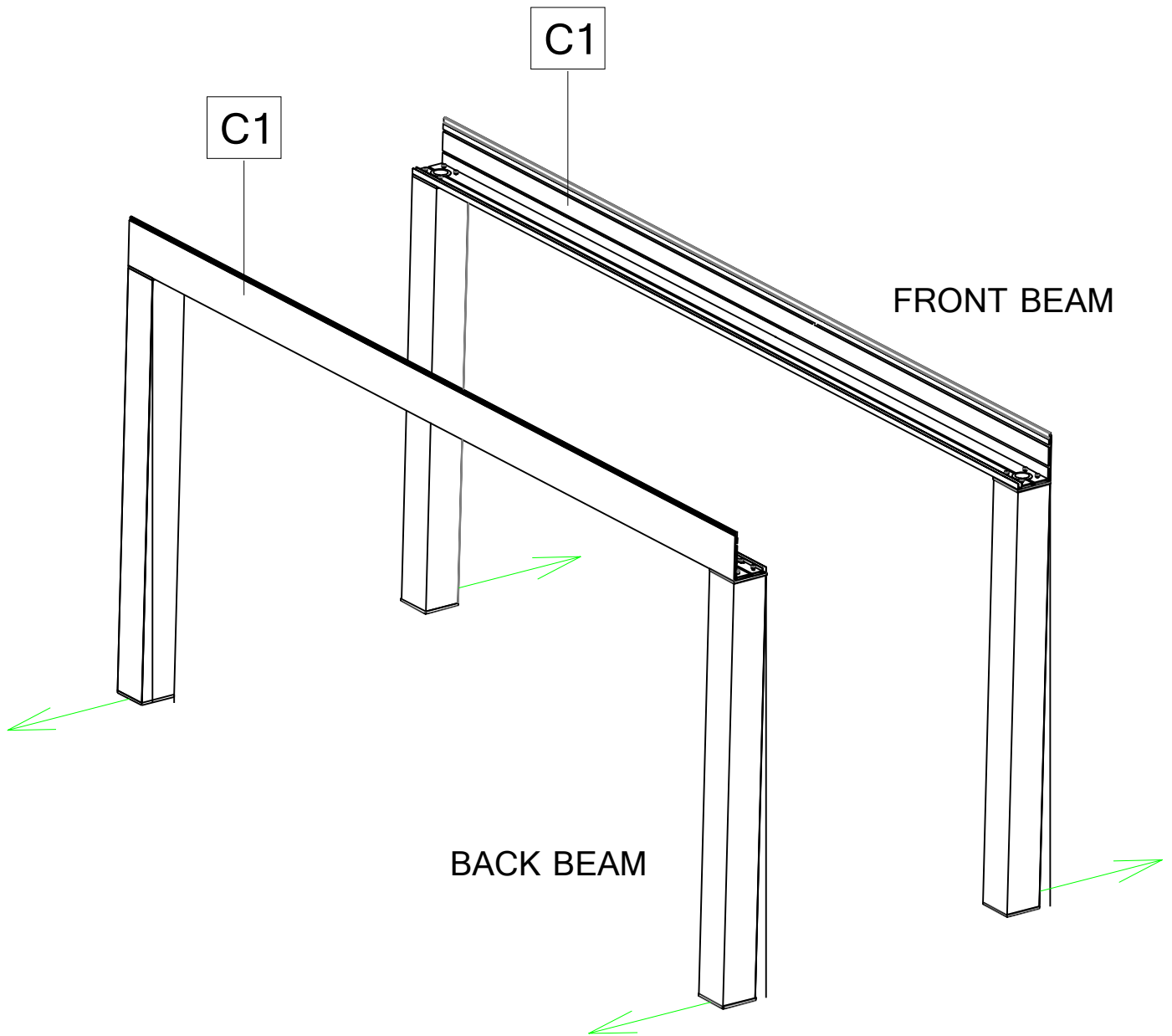

x2

POST & BEAM PROFILE GROUPS



# Step 1

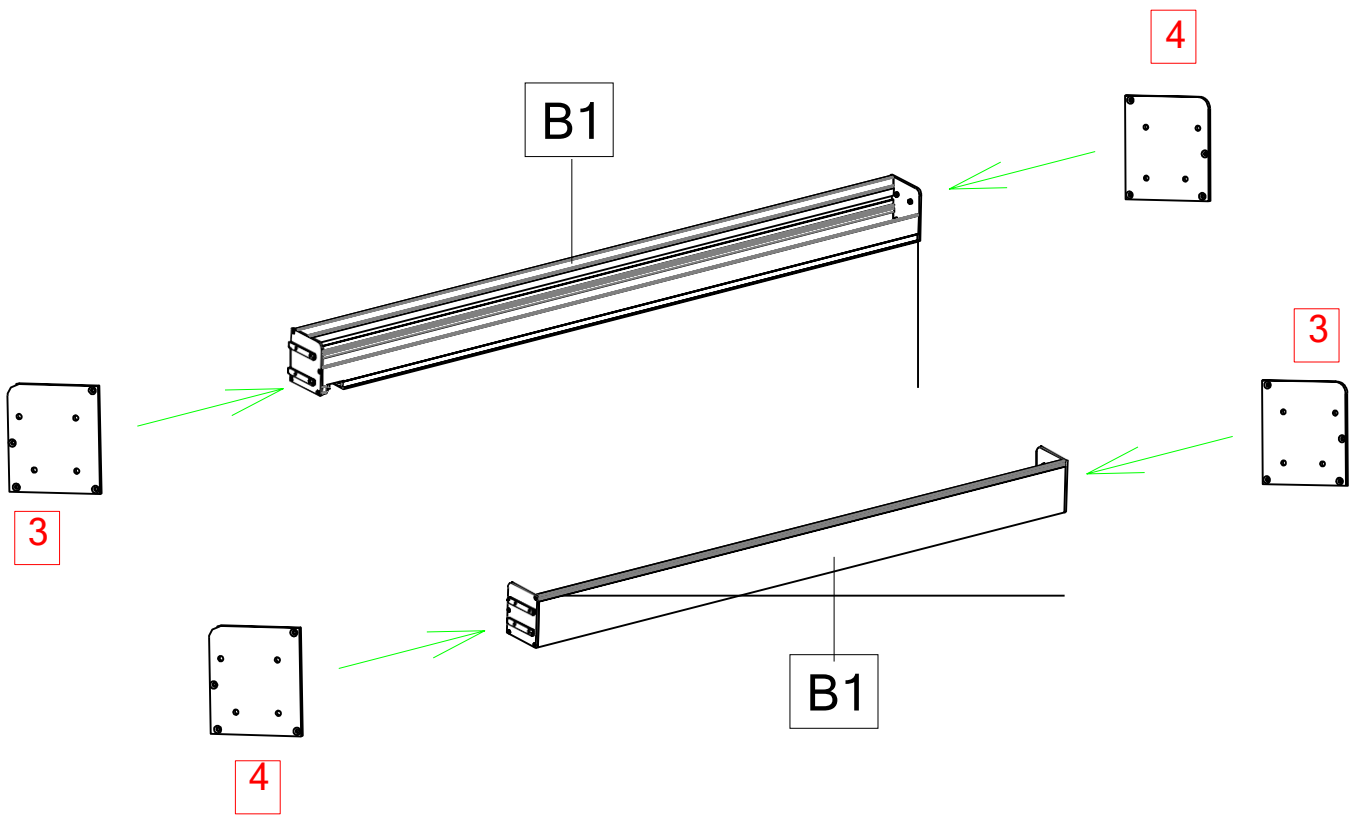

x2

RAIL PROFILE GROUPS

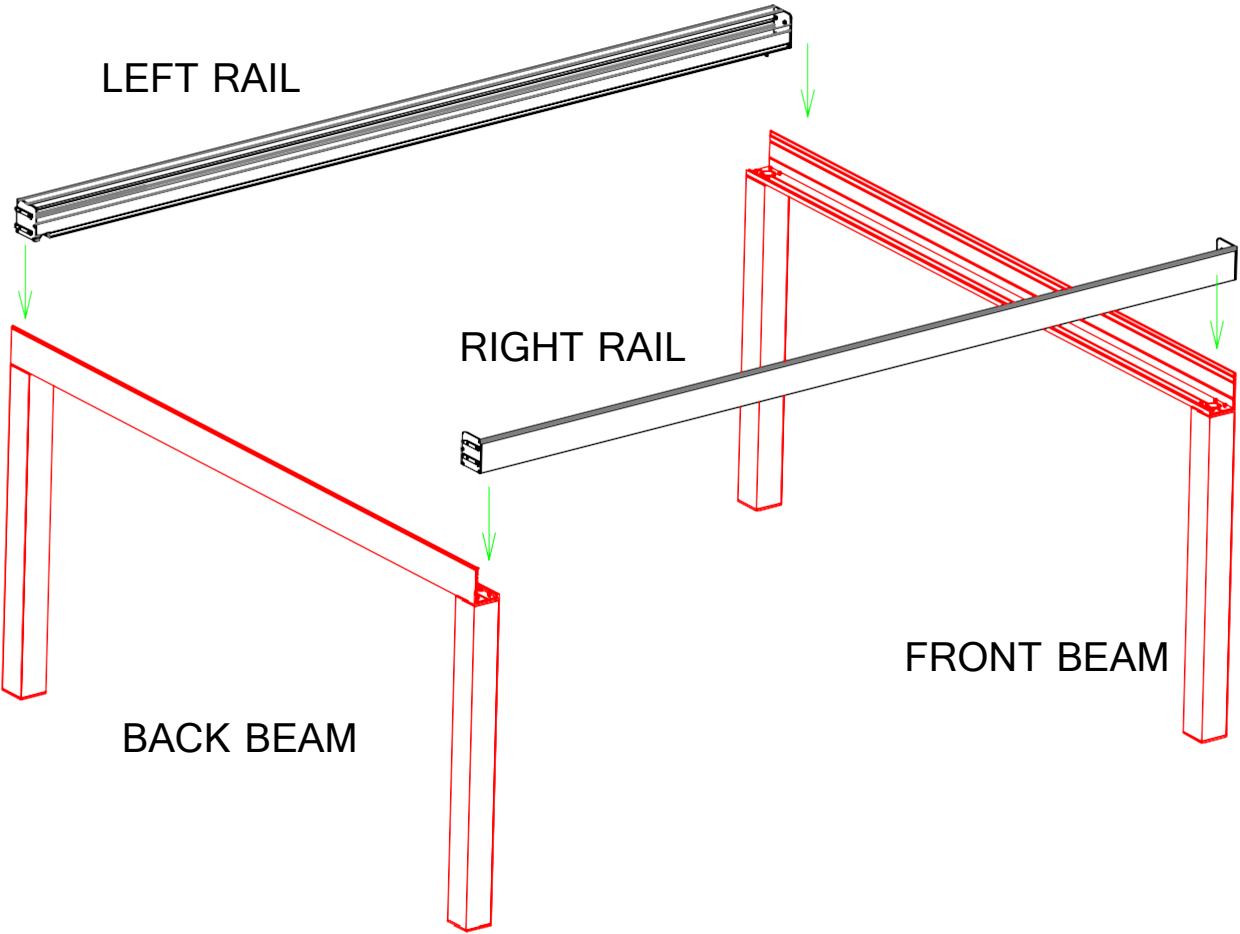

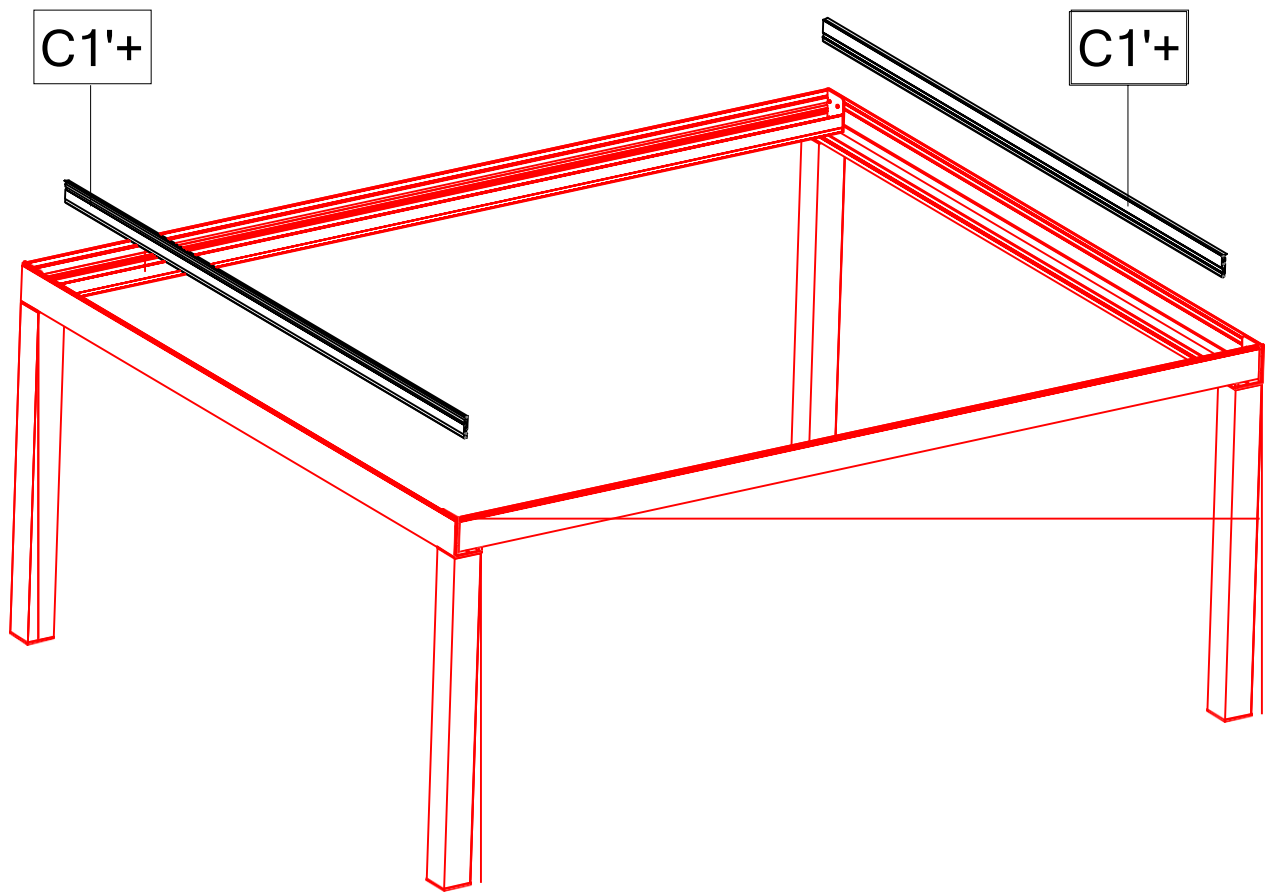

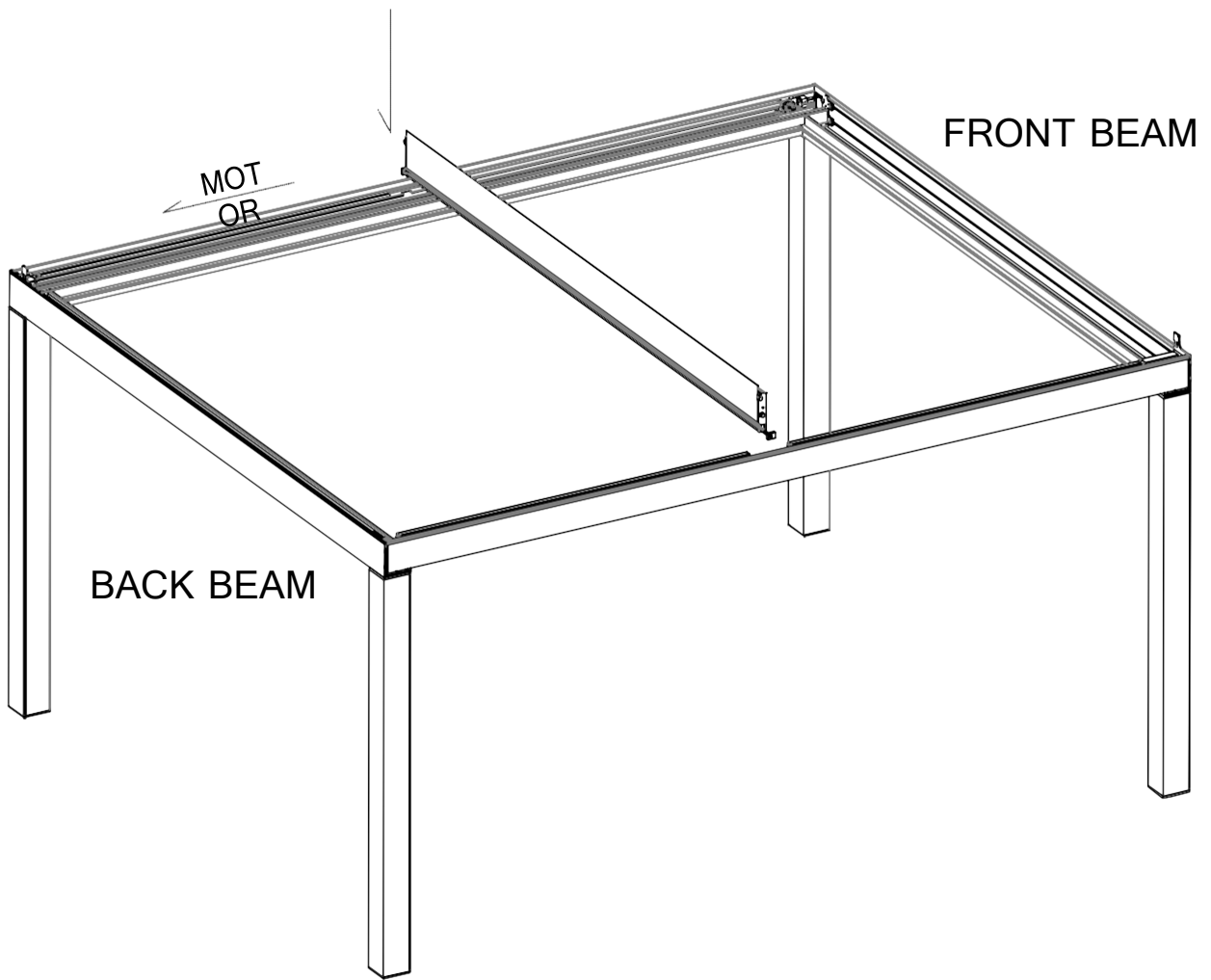

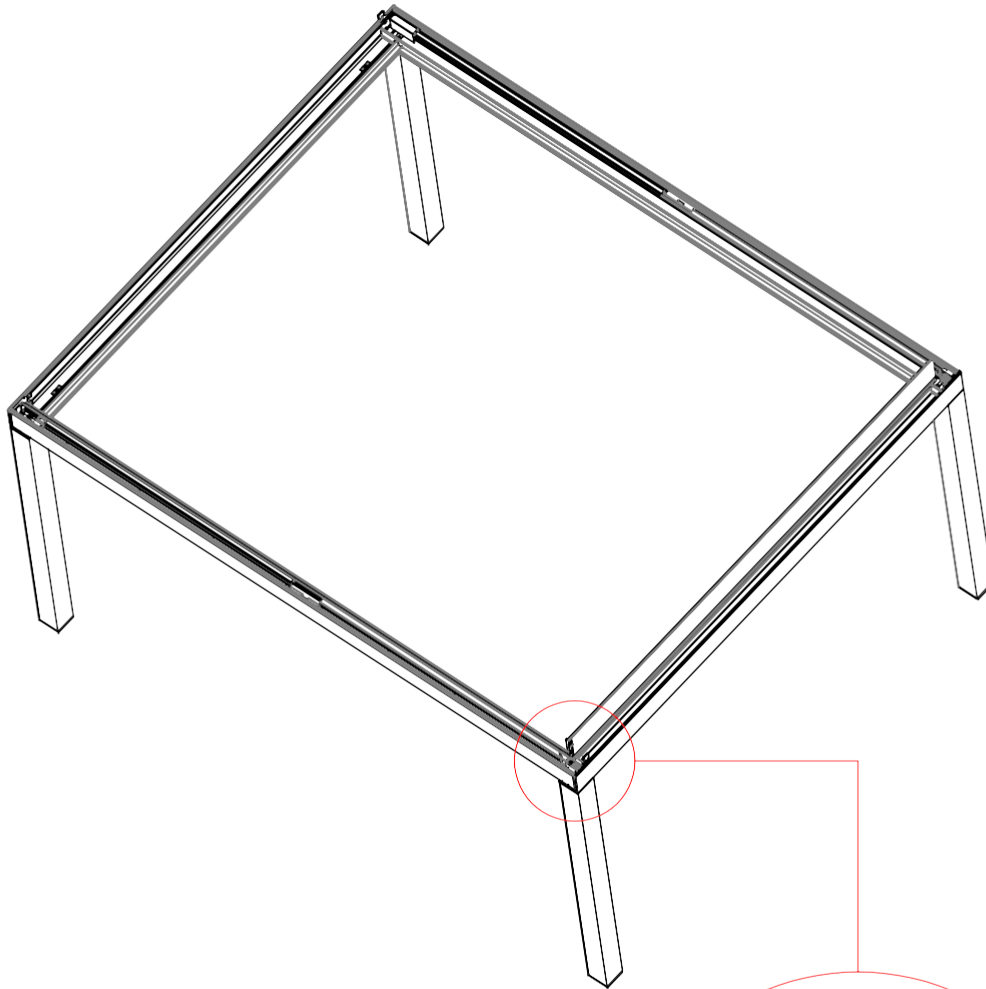

"FIXED LOUVER" FIXING

M6 x 70 Imbus Bolt

M6 Washer

M6 Nut

X2

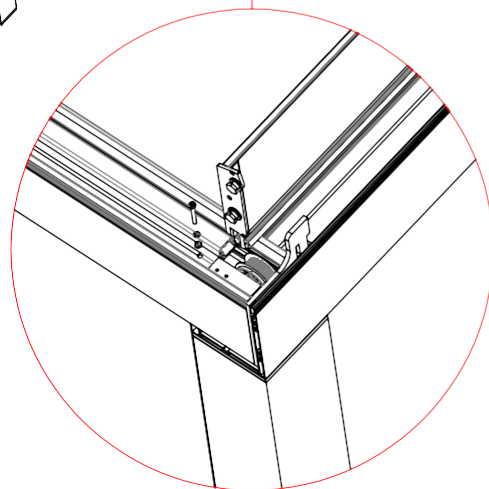

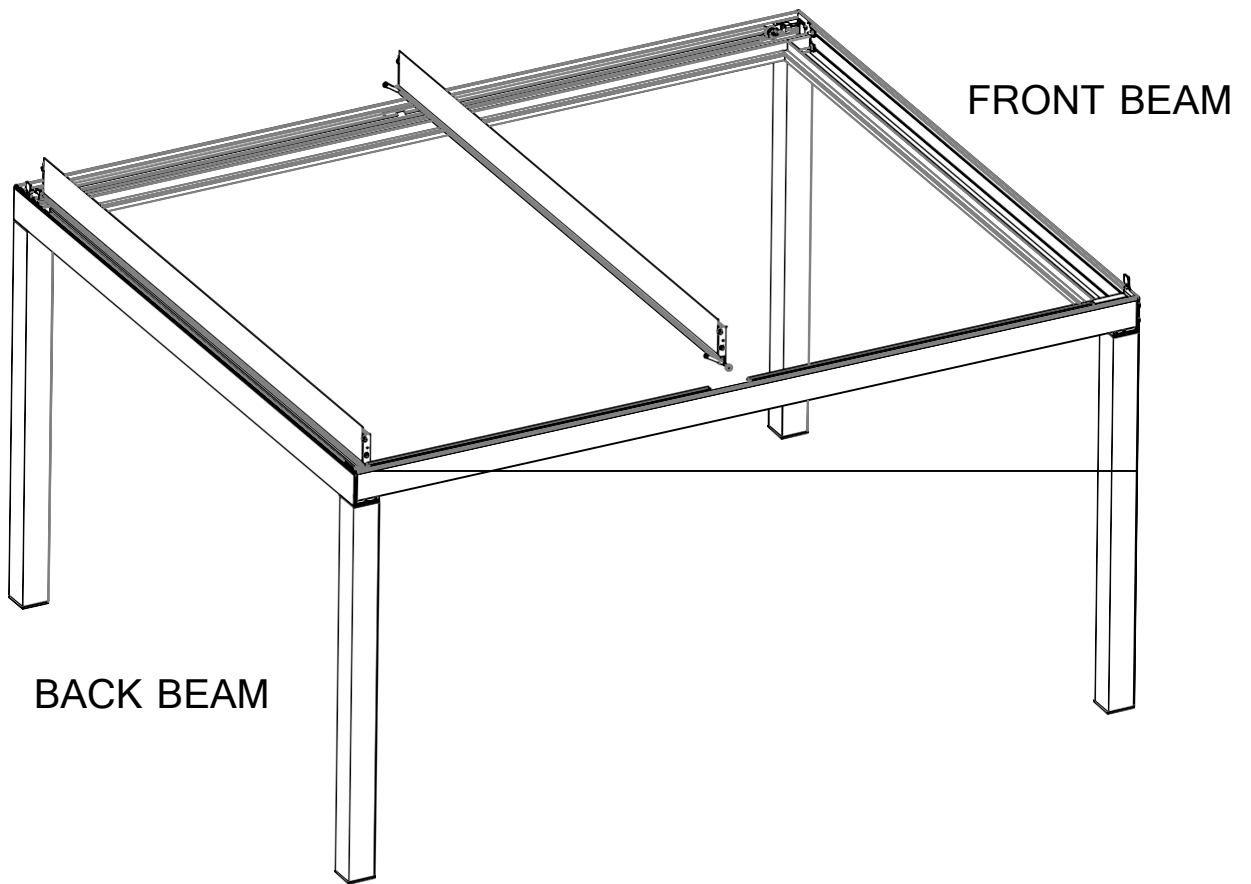

## Louver Installation Steps

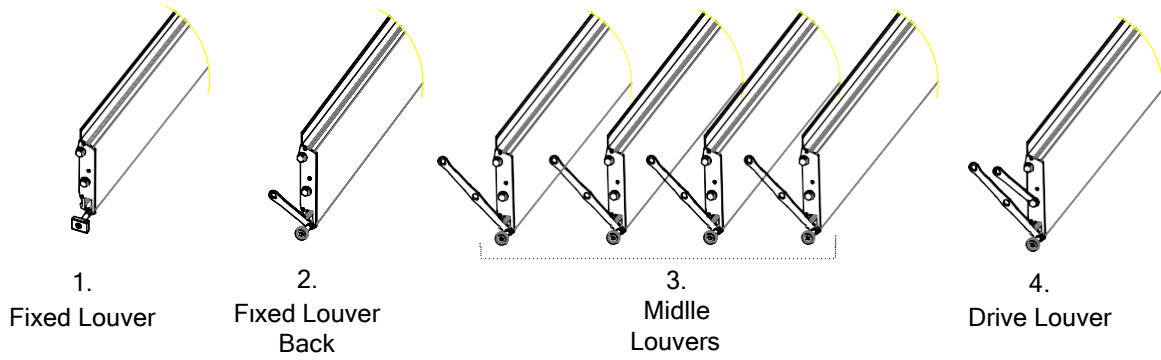

Towing Louver Timing-Belt Connector

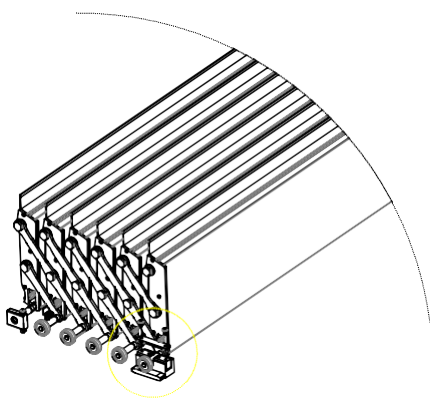

2 Pcs M6 x 16 Round Head Bolt

Clippers Installation Algorithm

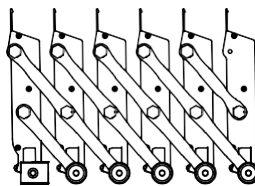

Clipper Installation

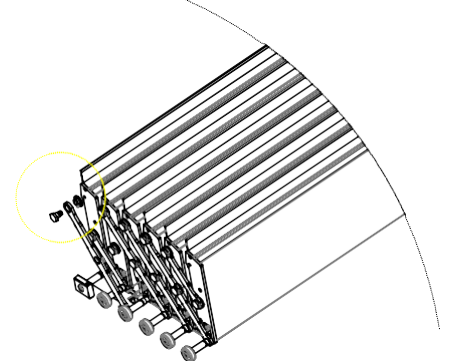

## TIMING -BELT COVER BOARD INSTALLATION

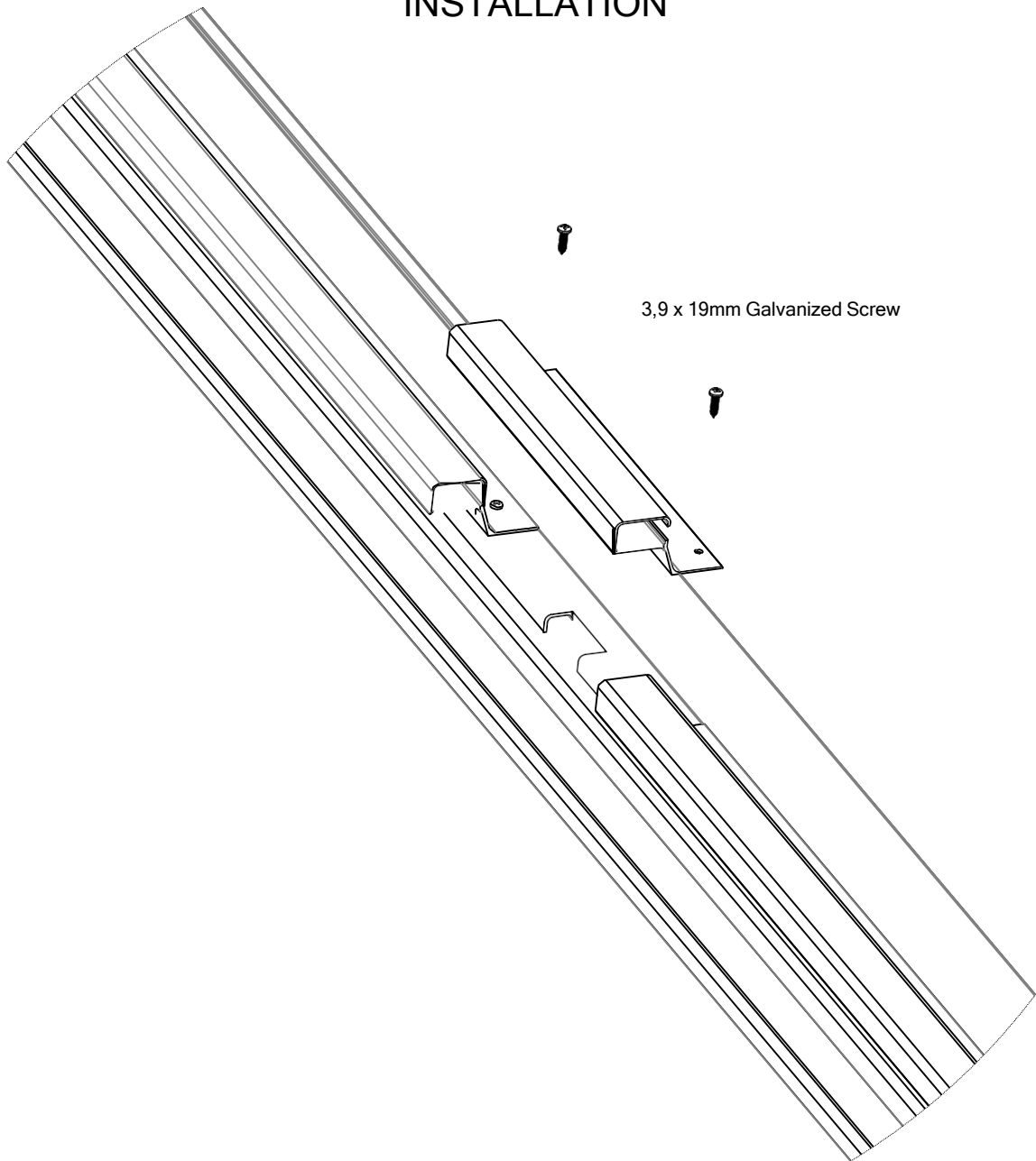



## MOTOR-SHAFT INSTALLATION

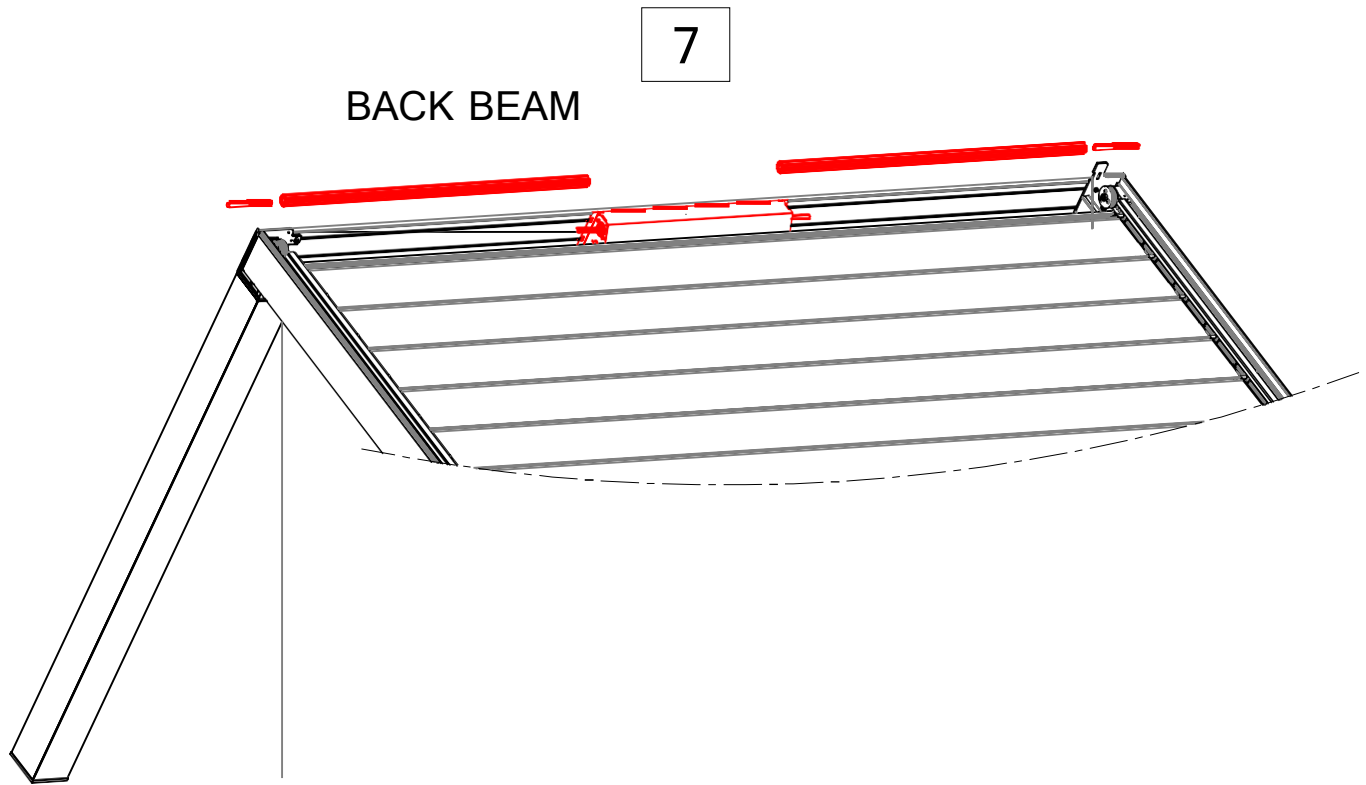

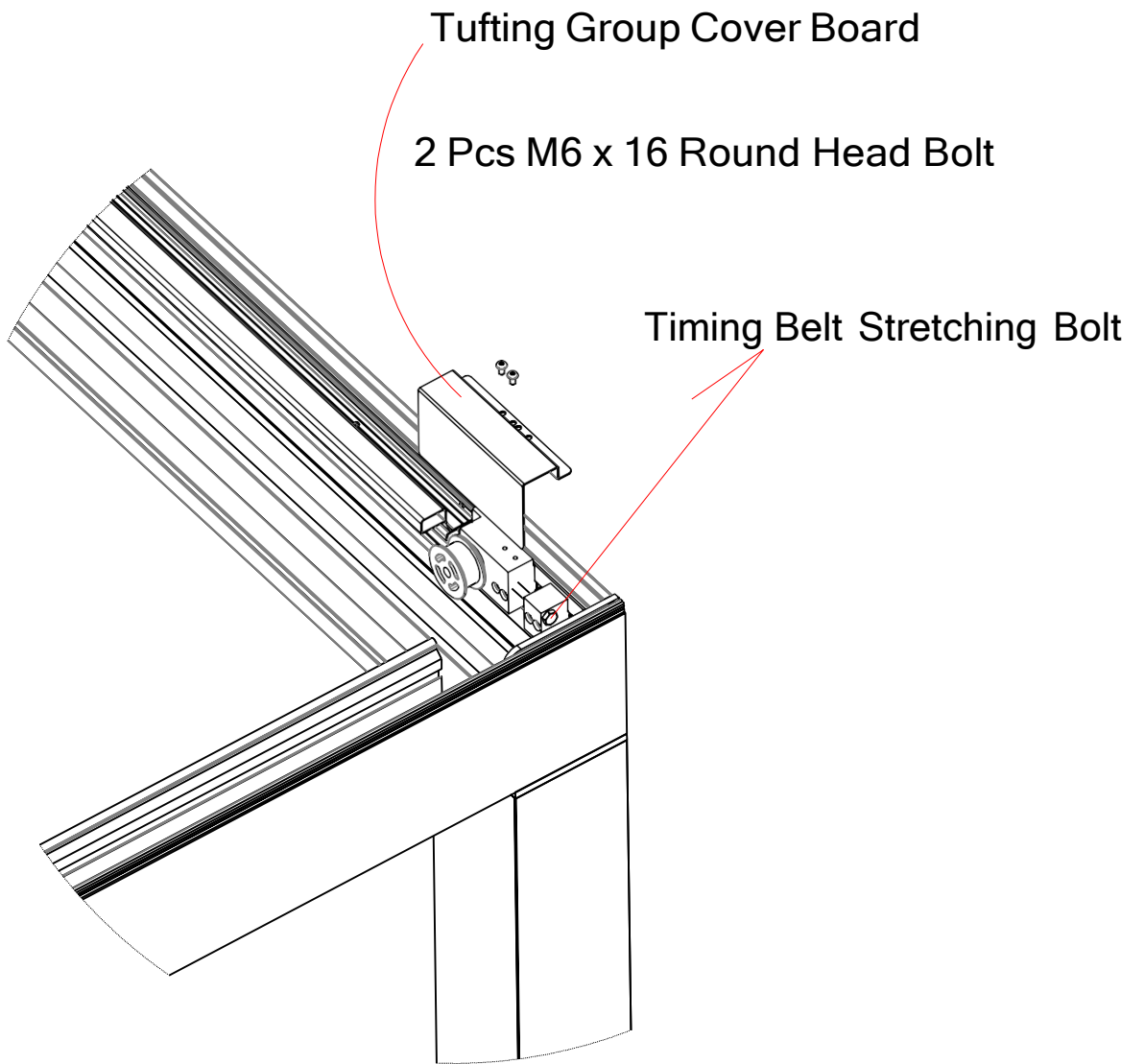

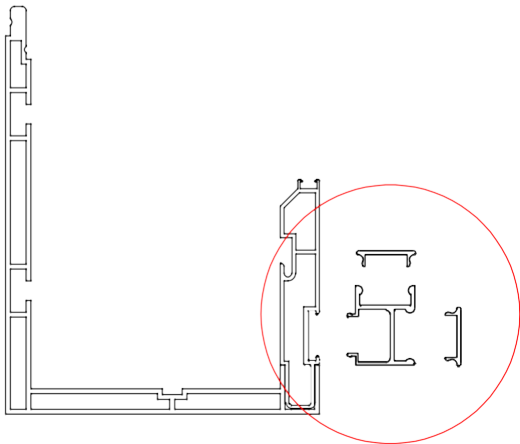
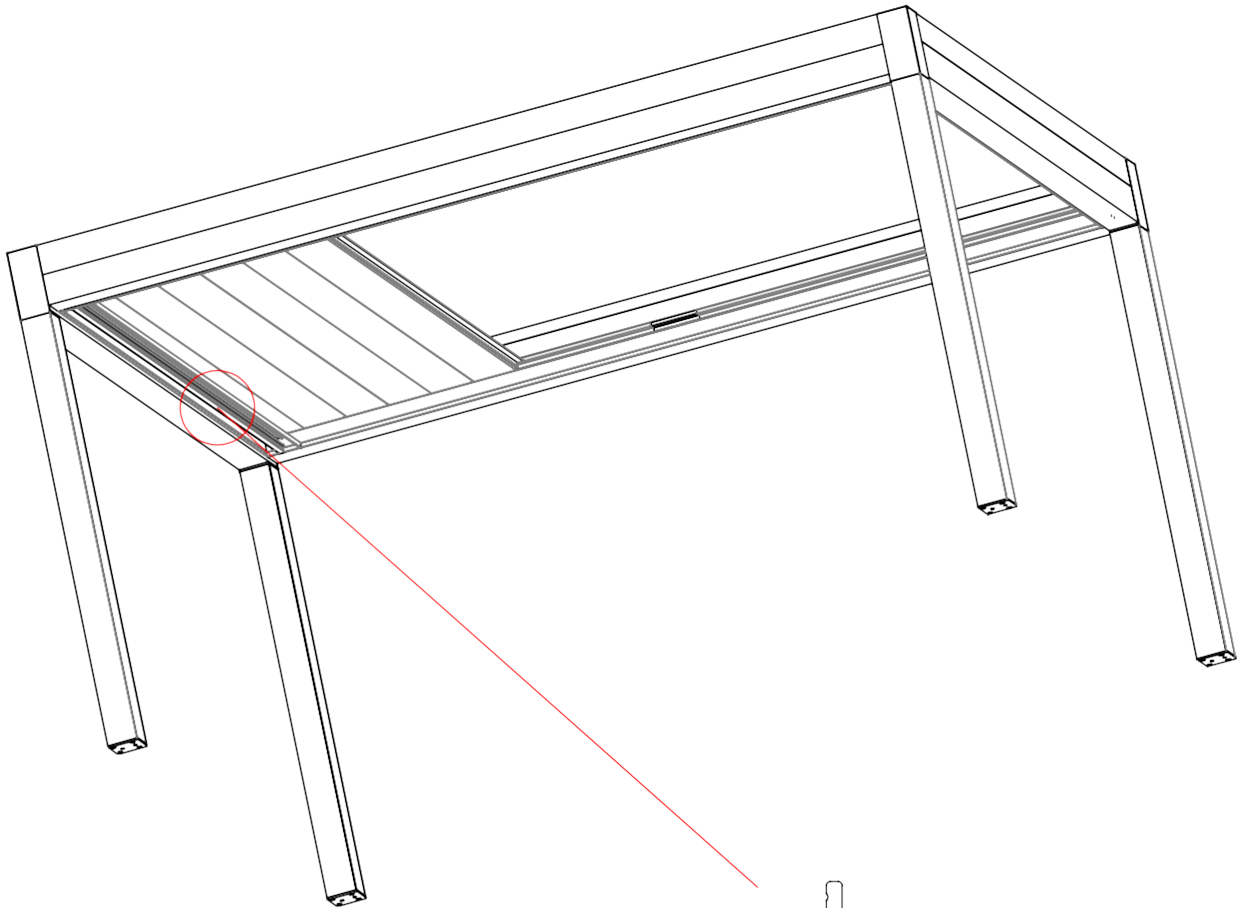

**Led Profile - Beam Profile Installation**

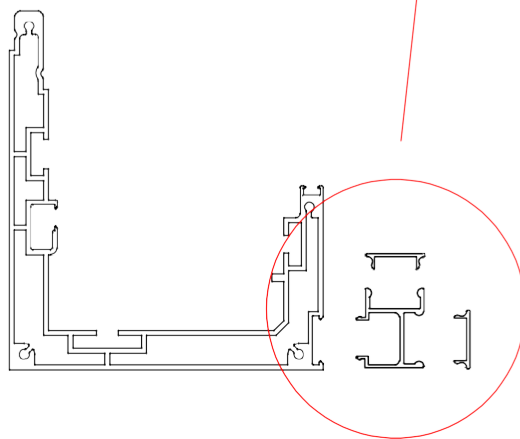
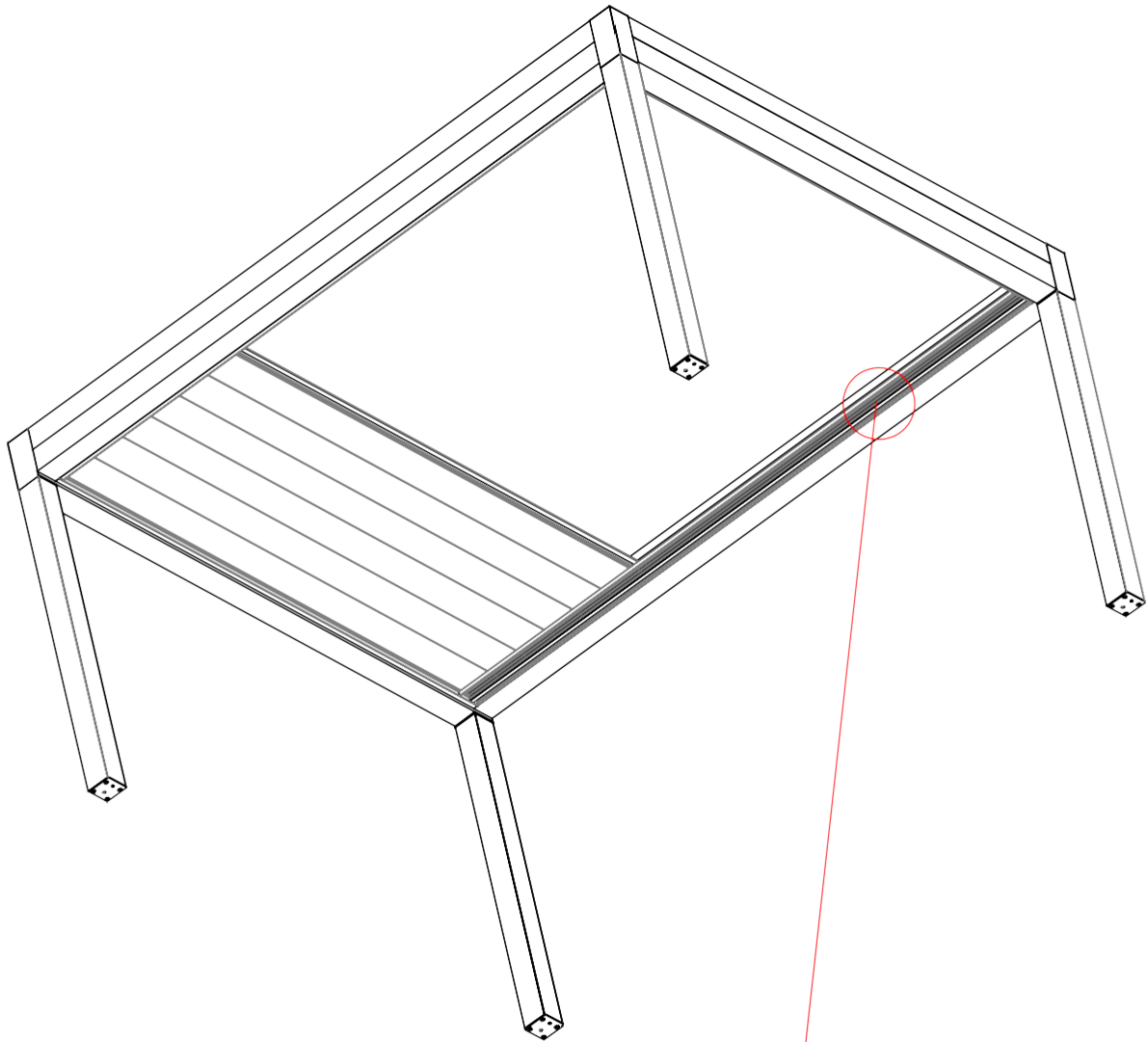

Led Profile - Rail profile Installation

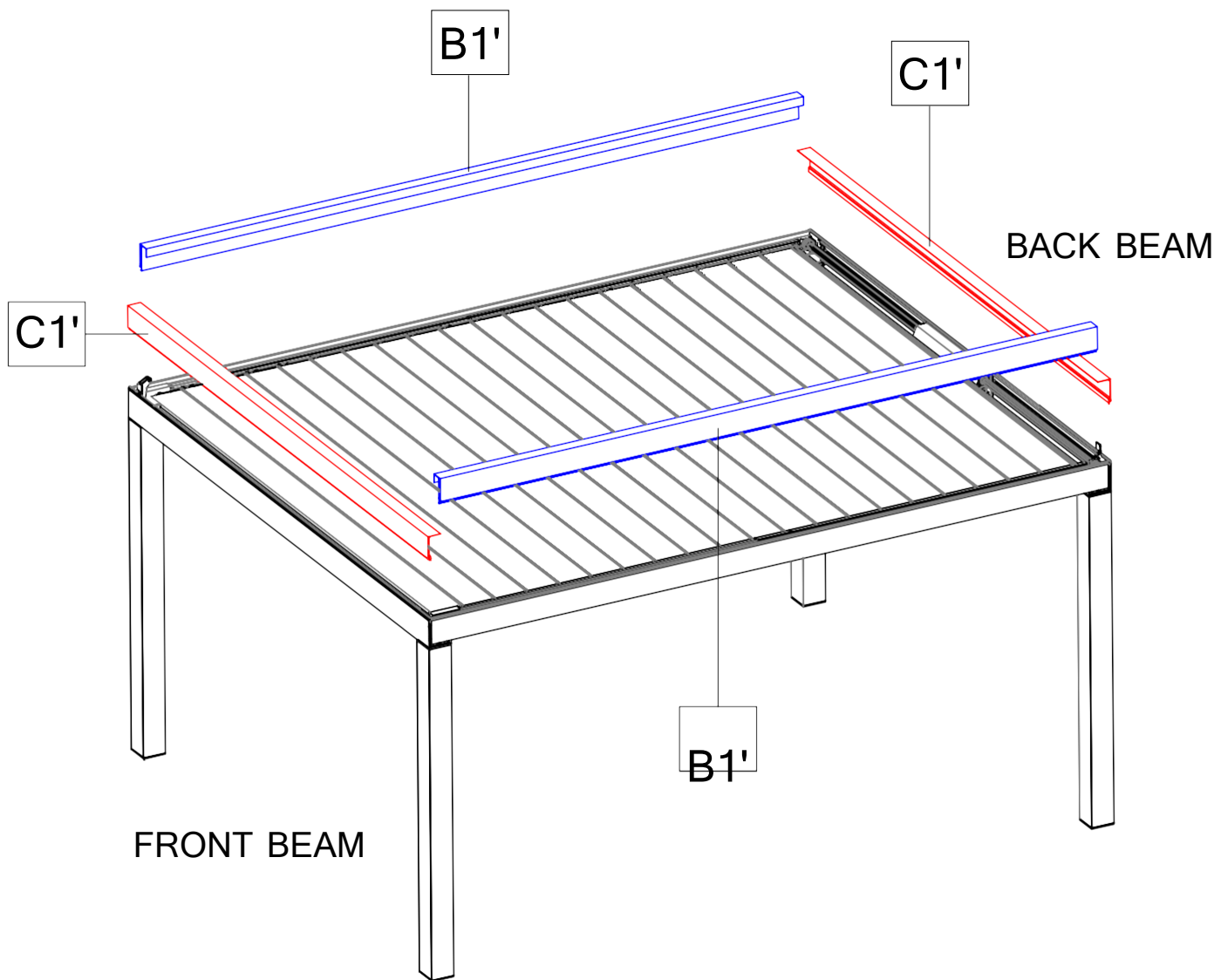

## Corner Cover Installation

